



Model Number

NJ15-30GK50-A2

Features

- 15 mm non-flush

Accessories

BF 30

Mounting flange, 30 mm

Technical Data

General specifications

Switching element function		PNP	NO/NC
Rated operating distance	s_n	15 mm	
Installation		non-flush	
Output polarity		DC	
Assured operating distance	s_a	0 ... 12.15 mm	
Reduction factor r_{Al}		0.4	
Reduction factor r_{Cu}		0.38	
Reduction factor r_{304}		0.71	
Reduction factor r_{Brass}		0.45	

Nominal ratings

Operating voltage	U_B	10 ... 60 V
Switching frequency	f	0 ... 300 Hz
Hysteresis	H	typ. 5 %
Reverse polarity protection		reverse polarity protected
Short-circuit protection		pulsing
Voltage drop	U_d	≤ 2.8 V
Operating current	I_L	0 ... 400 mA
Off-state current	I_r	0 ... 0.5 mA typ. 0.01 mA
No-load supply current	I_0	≤ 9 mA
Switching state indicator		LED, yellow

Functional safety related parameters

MTTF _d	1120 a
Mission Time (T _M)	20 a
Diagnostic Coverage (DC)	0 %

Ambient conditions

Ambient temperature	-25 ... 70 °C (-13 ... 158 °F)
Storage temperature	-25 ... 85 °C (-13 ... 185 °F)

Mechanical specifications

Connection type	cable PVC , 2 m
Core cross-section	0.75 mm ²
Housing material	PBT
Sensing face	PBT
Protection degree	IP68

Compliance with standards and directives

Standard conformity	
Standards	EN 60947-5-2:2007 IEC 60947-5-2:2007

Approvals and certificates

UL approval	cULus Listed, General Purpose
CSA approval	cCSAus Listed, General Purpose
CCC approval	Certified by China Compulsory Certification (CCC)

Dimensions

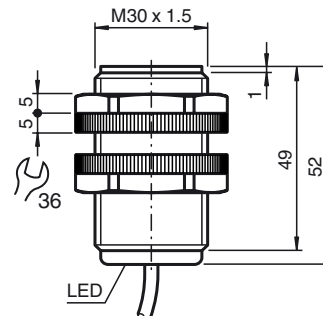

Electrical Connection

